

ESTRUCTURA

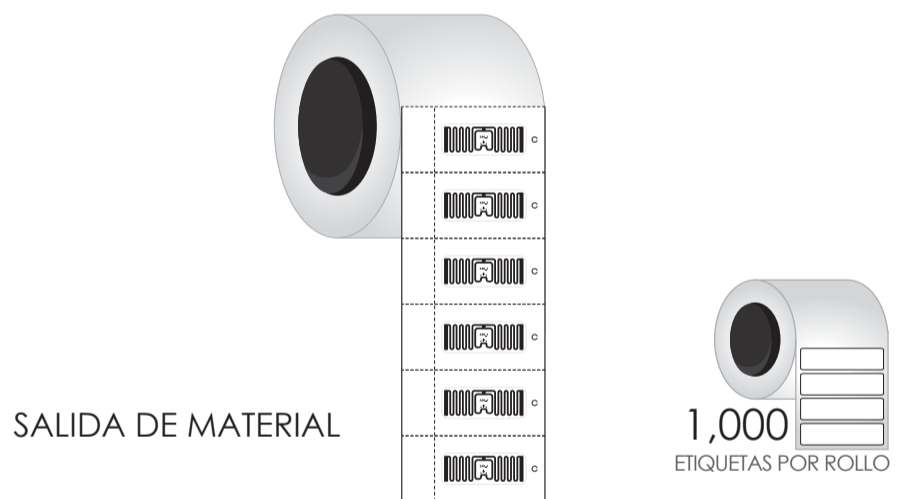
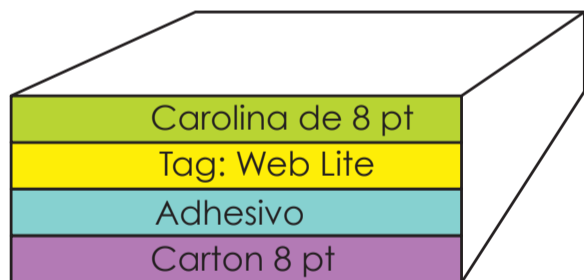

DESCRIPCIÓN:

Etiqueta Hang Tag de carton en blanco 3.31 " x 1.52 " (83mm x 38mm)
con perforación de 3 mm. al centro.
Material: Carolina de 8pt, Bobina Central 3.

PANTONES

■ BLACK

Corte completo

CARACTERÍSTICAS ELÉCTRICAS:

Circuito Integrado (IC)	Impinj Monza5
Protocolo de Interface	EPC Class 1 Gen 2, ISO 18 000-6C
Frecuencia de Operación	860 - 960 MHz
Memoria	128 bit EPC